



NEW

# DINGO SERIES

## AIR OPERATED DIAPHRAGM PUMPS

## PRODUCT OVERVIEW

The new Dingo Series of Air Operated Diaphragm Pumps are the ideal pumps for transferring & dispensing diesel, oil, waste oil, ATF, coolant, antifreeze, petrol, wastewater, industrial sludge & some compatible chemicals.

Designed and built to work in the harshest conditions and locations, and of mine site specification quality, look no further than the Dingo Series of Air Operated Diaphragm Pumps from Alemcube. Manufactured with an aluminium body & PTFE diaphragms and balls as standard, the Dingo Series is designed to be compatible and handle more fluids than other standard diaphragm pumps that are typically

supplied with Hytrel, Geolast, or Buna diaphragms and balls. The Dingo Series of pumps are also all ideal for mine site application.

Matching the leading brand on the market, the pump is 100% interchangeable with the same mounting bracket and bolt holes for fast retrofitting.

For safety, the Dingo Series pumps incorporate a bolt through fluid cover to minimise leaks & make the pump more reliable and even safer. CE approved & compliant to ISO9001 Standards and with two major repair kits readily available.



## KEY FEATURES

- **Suitable for multiple fluid transfer applications**  
Ideal for mine site application
- **Safe bolt through fluid cover**  
minimising leaks and making the pump more reliable and even safer to use
- **CE approved & compliant**  
To ISO9001 standards
- **Fast retrofit capability**  
100% interchangeable with 2 major repair kits to assist with pump maintenance, site productivity & profitability
- **Fast & easy maintenance**  
Two major repair kits available for all models
- **Built to mine site quality & specifications**  
Designed & built to work in the harshest conditions & locations

# PRODUCT SPECIFICATIONS



**AD12AT**

Dingo 1/2" Air Operated Diaphragm Pump

**AD20AT**

Dingo 3/4" Air Operated Diaphragm Pump

**AD25AT**

Dingo 1" Air Operated Diaphragm Pump

**AD40AT**

Dingo 1-1/2" Air Operated Diaphragm Pump

**AD50AT**

Dingo 2" Air Operated Diaphragm Pump

PRODUCT NO.	FLOW RATES	OPERATING PRESSURE	DELIVERY PER CYCLE	AIR INLET	INLET/OUTLET FLUID	MAXIMUM SUSPENDED SOLIDS DIAMETER	BODY	DIAPHRAGMS + BALLS
AD12AT	56.7L/min	100psi (6.9bar)	150ml	1/4" BSPF	1/2" BSPF	2.5mm	Aluminium	PTFE (Teflon)
AD20AT	61L/min	100psi (6.9bar)	150ml	1/4" BSPF	3/4" BSPF	2.5mm	Aluminium	PTFE (Teflon)
AD25AT	159L/min	120psi (8bar)	570ml	1/2" BSPF	1" BSPF	3.2mm	Aluminium	PTFE (Teflon)
AD40AT	378L/min	120psi (8bar)	1.9L	1/2" BSPF	1-1/2" BSPF	4.8mm	Aluminium	PTFE (Teflon)
AD50AT	568L/min	120psi (8bar)	3.9L	1/2" BSPF	2" BSPF	6.3mm	Aluminium	PTFE (Teflon)

## DIMENSIONS

See Product Information sheet for further details

### AD12AT & AD20AT

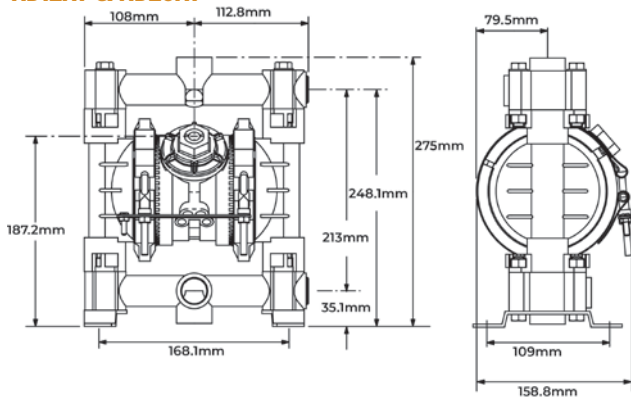

### AD25AT

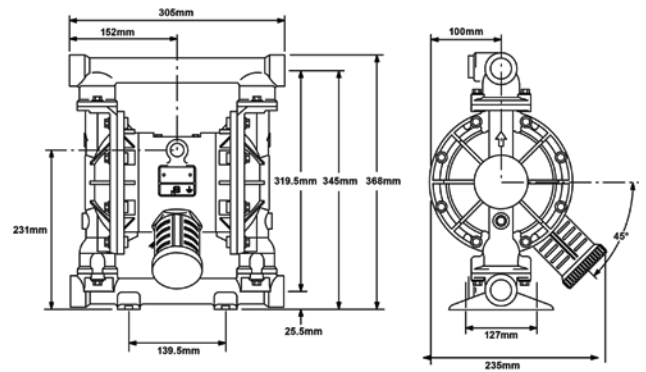

### AD40AT

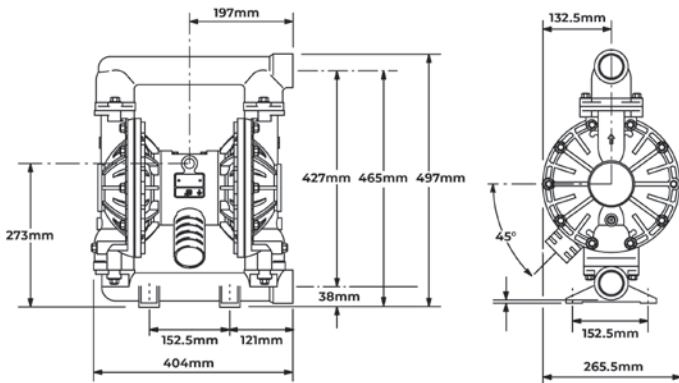

### AD50AT

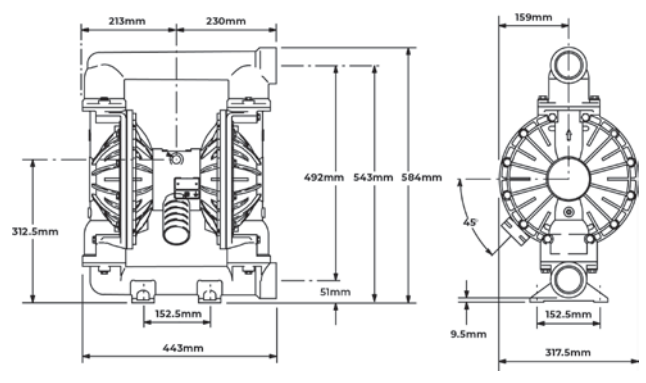

NSW/ACT (02) 9677 1555  
WA (08) 9302 4199

QLD/PNG (07) 3491 2600  
SA/NT (08) 8241 7111

VIC/TAS (03) 8787 8288  
NZ (09) 447 1007

[www.alemlube.com.au](http://www.alemlube.com.au)  
[www.alemlube.co.nz](http://www.alemlube.co.nz)

